



2 pólus - 3000/3600 ford./perc

	Termék választék				Mechanikus tulajdonságok						Elektromos tulajdonságok					
	Kód	Típusjel	Építési nagyság	II2D Hőm. osztály	Statikus nyomaték*		Centrifugális erő				Tömeg		Max. teljesítmény		Max. áram	
					kgmm	kgmm	kg	kg	kN	kN	kg	kg	W	W	A	A
Három fázisú	600311	MVISI 3/100-S02	00	• 120°C	12.0	12.0	121	174	1.19	1.71	5.60	5.60	180	180	0.35	0.30
	600312	MVISI 3/200-S02	01	• 120°C	21.0	15.0	211	218	2.07	2.14	6.40	6.20	180	180	0.35	0.30
	600313	MVISI 3/300-S02	10	• 120°C	30.1	20.4	304	297	2.98	2.91	9.70	9.20	260	270	0.60	0.50
	600314	MVISI 3/500-S02	20	• 120°C	49.9	32.4	503	471	4.93	4.62	14.8	13.8	450	500	0.80	0.75
	600366	MVISI 3/700-S02	20	• 120°C	72.8	-	734	-	7.19	-	15.1	-	450	-	0.8	-
	600381	MVISI 3/800-S02	30	• 120°C	78.0	52.0	785	754	7.70	7.40	21.0	20.0	650	685	1.10	1.00
	600513	MVISI 3/1100-S02	35	• 120°C	110	73.0	1105	1061	10.8	10.4	23.0	22.0	1000	1200	1.75	1.75
	600491	MVISI 3/1300-S08	AF33	• 200°C	128	91.6	1290	1327	12.7	13.0	27.0	25.7	1300	1350	2.10	1.90
	600504	MVISI 3/1500-S08	AF33	• 200°C	146	110	1470	1595	14.4	15.6	25.3	24.0	1300	1350	2.10	1.90
	600502	MVISI 3/1600-S02	50	• 200°C	153	102	1545	1483	15.2	14.5	33.0	31.5	1400	1450	2.30	2.00
	600503	MVISI 3/1800-S02	50	• 200°C	179	128	1802	1853	17.7	18.2	34.0	32.5	2000	2000	3.30	2.90
	600256	MVISI 3/2010-S90	AF50	• 200°C	205	128	2059	1853	20.2	18.2	48.7	46.3	2200	2200	3.50	3.00
	600257	MVISI 3/2310-S90	AF50	• 200°C	230	153	2316	2224	22.7	21.8	49.6	47.1	2200	2200	3.50	3.00
	600470	MVISI 3/3200-S02	AF70	• 135°C	344	215	3457	3112	33.9	30.5	94.0	90.0	4000	4000	6.50	5.60
	600471	MVISI 3/4000-S02	AF70	• 135°C	387	258	3890	3735	38.2	36.6	96.0	92.0	4000	4000	6.50	5.60
	600472	MVISI 3/5000-S02	AF70	• 135°C	515	344	5187	4979	50.9	48.8	109	105	5000	5000	7.60	6.90
	600276	MVISI 3/6510-S02	90	• 135°C	630	443	6357	6420	62.4	63.0	184	178	5500	5500	9.20	8.00
	600201	MVISI 3/9000-S90	95	- 135°C	895	619	9007	8970	88.4	88.0	215	210	10000	9300	18.0	13.0
Egy fázisú	600311	MVISI 3/100-S02	00	• 120°C	12.0	12.0	121	174	1.19	1.71	5.60	5.60	165	165	0.75	1.52
	600312	MVISI 3/200-S02	01	• 120°C	21.0	15.0	211	218	2.07	2.14	6.40	6.20	165	165	0.75	1.52
	600313	MVISI 3/300-S02	10	• 120°C	30.1	20.4	304	297	2.98	2.91	9.70	9.20	280	280	1.25	2.40
	600314	MVISI 3/500-S02	20	• 120°C	49.9	32.4	503	471	4.93	4.62	14.8	13.8	500	500	2.30	4.50
	600366	MVISI 3/700-S02	20	• 120°C	72.8	-	734	-	7.19	-	15.1	-	500	-	2.30	-
	600381	MVISI 3/800-S02	30	• 120°C	78.0	52.0	785	754	7.70	7.40	16.8	15.9	700	750	3.25	7.00

* Üzemi nyomaték = 2 x statikus nyomaték.

Ábra: A

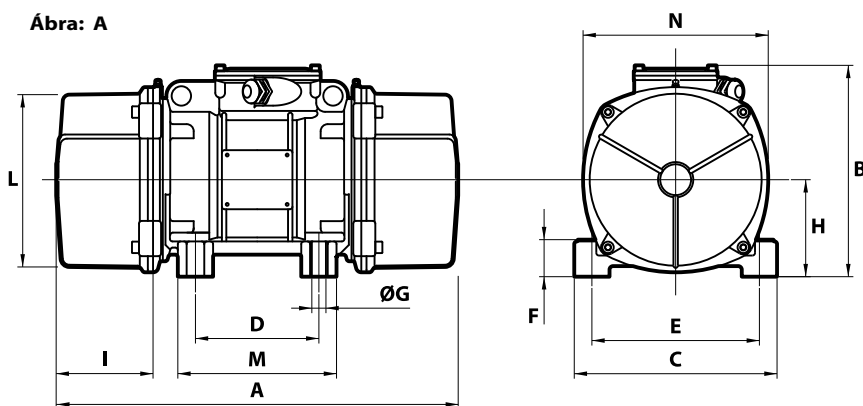

I _a /I _n		Tipusjel	Méretek (mm)													Kondenzátor (µF)		Kábel bevez.	
50 Hz	60 Hz		Ábra	A	B	C	D	E	ØG	N°	F	H	I	L	M	N	220 V 50 Hz		115 V 60 Hz
2.68	3.00	MVSI 3/100-S02	A	211	153	125	62-74**	106	9	4	24	61	46	103	100	117	-	-	M20x1,5
2.68	3.00	MVSI 3/200-S02	A	235	153	125	62-74**	106	9	4	24	61	58	103	100	117	-	-	M20x1,5
3.47	4.20	MVSI 3/300-S02	A	255	179	152	90	125	13	4	28	73	54	127	128	141	-	-	M20x1,5
4.21	4.80	MVSI 3/500-S02	A	288	203	167	105	140	13	4	30	82.5	65	145	140	160	-	-	M25x1,5
4.21	-	MVSI 3/700-S02	A	288	203	167	105	140	13	4	30	82.5	65	145	140	160	-	-	M25x1,5
3.83	6.00	MVSI 3/800-S02	A	308	216	205	120	170	17	4	45	93.5	63	170	160	182	-	-	M25x1,5
3.63	4.00	MVSI 3/1100-S02	A	435	225	205	120	170	17	4	54	104.5	117,5	187	162	203	-	-	M25x1,5
3.96	4.98	MVSI 3/1300-S08	A	375	216.5	215	100	180	17	4	47	93,5	106	170	145	182	-	-	M25x1,5
3.96	4.98	MVSI 3/1500-S08	A	375	216.5	215	100	180	17	4	47	93,5	106	170	145	182	-	-	M25x1,5
4.95	6.12	MVSI 3/1600-S02	A	430	246	230	140	190	17	4	54	116	99	207	190	225	-	-	M25x1,5
4.33	5.50	MVSI 3/1800-S02	A	430	246	230	140	190	17	4	54	116	99	207	190	225	-	-	M25x1,5
4.62	6.00	MVSI 3/2010-S90	A	465	230	230	140	190	17	4	49	104	105	186	180	200	-	-	M25x1,5
4.62	6.00	MVSI 3/2310-S90	A	465	230	230	140	190	17	4	49	104	105	186	180	200	-	-	M25x1,5
4.46	5.18	MVSI 3/3200-S02	A	560	290	310	155	255	25	4	90	130	137	238	210	253	-	-	M25x1,5
4.46	5.18	MVSI 3/4000-S02	A	560	290	310	155	255	25	4	90	130	137	238	210	253	-	-	M25x1,5
5.54	7.10	MVSI 3/5000-S02	A	560	290	310	155	255	25	4	90	130	137	238	210	253	-	-	M25x1,5
6.45	7.20	MVSI 3/6510-S02	A	680	370	390	200	320	28	4	90	180	160	330	270	350	-	-	M32x1,5
4.39	5.23	MVSI 3/9000-S90	A	629	395	392	200	320	28	4	100	192	135	355	270	375	-	-	M32x1,5

Három fázisú

Egy fázisú

I_a/I_n = Indító / max. névleges áram.

** Egyes modellek rögzítése a talp lyuk ovális kialakítása miatt több méretben is lehetséges.



4 Pólus - 1500/1800 ford./perc

	Termék választék				Mechanikus tulajdonságok						Elektromos tulajdonságok					
	Kód	Típusjel	Építési nagyság	II2D Hőm. osztály	Statikus nyomaték* kgmm		Cenrifugális erő				Tömeg kg		Max. teljesítmény W		Max. áram A	
					50 Hz	60 Hz	50 Hz	60 Hz	50 Hz	60 Hz	50 Hz	60 Hz	50 Hz	60 Hz	400 V 50 Hz	460 V 60 Hz
Három fázisú	601340	MVISI 15/35-S02	00	• 120°C	12.0	12.0	30.2	43.5	0.30	0.43	5.60	5.60	85	95	0.21	0.20
	601341	MVISI 15/80-S02	01	• 120°C	31.0	21.0	77.9	76.1	0.76	0.75	6.70	6.40	85	95	0.21	0.20
	601366	MVISI 15/100-S02	01	• 120°C	38.9	31.0	97.9	112	0.96	1.10	7.10	6.70	85	95	0.21	0.20
	601367	MVISI 15/200-S02	10	• 120°C	84.2	58.8	213	214	2.09	2.10	12.5	11.7	170	170	0.41	0.40
	601372	MVISI 15/400-S02	20	• 120°C	163	113	412	411	4.04	4.03	19.0	18.2	300	350	0.60	0.60
	601373	MVISI 15/550-S02	20	• 120°C	219	163	552	592	5.42	5.81	20.4	19.0	300	350	0.60	0.60
	601408	MVISI 15/700-S02	30	• 120°C	286	209	720	760	7.06	7.46	27.5	26.2	525	665	0.92	0.98
	601513	MVISI 15/900-S02	30	• 120°C	357	286	900	1037	8.83	10.2	30.0	27.5	525	665	0.92	0.98
	601524	MVISI 15/1100-S02	35	• 120°C	415	271	1045	982	10.3	9.63	35.0	30.5	550	680	0.95	0.95
	601217	MVISI 15/1410-S02	40	• 120°C	561	400	1413	1449	13.9	14.2	44.0	41.0	900	1050	1.45	1.50
	601219	MVISI 15/1710-S02	50	• 150°C	715	485	1798	1757	17.6	17.2	51.0	48.5	1100	1200	2.00	1.90
	601267	MVISI 15/2000-S02	50	• 170°C	817	561	2054	2033	20.1	19.9	55.5	51.5	1350	1450	2.50	2.30
	601220	MVISI 15/2410-S08	60	• 150°C	962	674	2420	2444	23.7	24.0	71.0	66.0	1600	1700	3.20	3.00
	601268	MVISI 15/3000-S08	60	• 135°C	1235	858	3106	3107	30.5	30.5	80.0	73.5	1900	2000	3.80	3.50
	601221	MVISI 15/3810-S02	70	• 135°C	1526	1034	3840	3744	37.7	36.7	119	110	2200	2500	3.90	3.90
	601269	MVISI 15/4300-S02	70	• 135°C	1720	1173	4326	4250	42.4	41.7	123	117	2500	2800	4.80	4.65
	601211	MVISI 15/5010-S02	80	• 135°C	1990	1364	5007	4941	49.1	48.5	161	153	3600	3400	6.00	5.00
	601447	MVISI 15/6000-S02	80	• 135°C	2248	1677	5654	6075	55.5	59.6	163.5	155	3600	3400	6.00	5.00
	601165	MVISI 15/7000-S02	90	• 135°C	2598	1822	6536	6600	64.1	64.7	208	195	6000	6000	10.5	9.00
	601166	MVISI 15/9000-S90	95	□ 135°C	3260	2260	8199	8183	80.4	80.3	225	210	7000	8000	11.6	11.5
601204	MVISI 15/9500-S02	97	□ 135°C	3346	2462	8416	8916	82.6	87.5	317	303	7500	8500	12.2	12.0	
601205	MVISI 15/11500-S90	100	□ 135°C	4544	3166	11430	11467	112	112	433	411	10000	10500	17.5	15.5	
601271	MVISI 15/14500-S90	100	□ 135°C	5614	4126	14120	14940	138	147	458	424	11000	12000	20.0	20.0	

	Kód	Típusjel	Építési nagyság	II2D Hőm. osztály	50 Hz	60 Hz	30.2	43.5	0.30	0.43	5.60	5.60	220 V	115 V		
													50 Hz	60 Hz	0.43	1.00
Egy fázisú	601340	MVISI 15/35-S02	00	• 120°C	12.0	12.0	30.2	43.5	0.30	0.43	5.60	5.60	90	100	0.43	1.00
	601341	MVISI 15/80-S02	01	• 120°C	31.0	21.0	77.9	76.1	0.76	0.75	6.70	6.40	90	100	0.43	1.00
	601366	MVISI 15/100-S02	01	• 120°C	38.9	31.0	97.9	112	0.96	1.10	7.10	6.70	90	100	0.43	1.00
	601367	MVISI 15/200-S02	10	• 120°C	84.2	58.8	213	214	2.09	2.10	12.5	11.7	210	230	1.00	2.00
	601372	MVISI 15/400-S02	20	• 120°C	163	113	412	411	4.04	4.03	19.0	18.2	240	320	1.20	2.80
	601373	MVISI 15/550-S02	20	• 120°C	219	163	552	592	5.42	5.81	20.4	19.0	240	320	1.20	2.80
	601408	MVISI 15/700-S02	30	• 120°C	286	209	720	760	7.06	7.46	27.5	26.2	450	550	2.15	5.15

* Üzemi nyomaték = 2 x statikus nyomaték. □ CSA-Tanusítvány külön kérésre.

Ábra: A

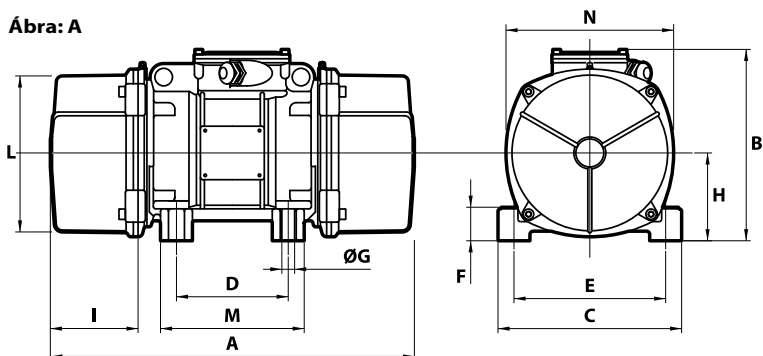

Ábra: C

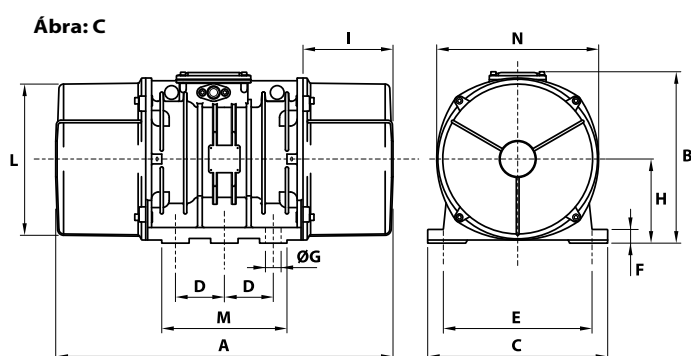

I _a /I _n 50 Hz 60 Hz		Típusjel	Méretek (mm)													Kondenzátor (µF)		Kábel bevez.	
			Ábra	A	B	C	D	E	Furat ØG N°		F	H	I	L	M	N	220 V 50 Hz		115 V 60 Hz
1.78	1.95	MVSI 15/35-S02	A	211	153	125	62-74**	106	9	4	24	61	46	103	100	117	-	-	M20x1,5
1.78	1.95	MVSI 15/80-S02	A	235	153	125	62-74**	106	9	4	24	61	58	103	100	117	-	-	M20x1,5
1.78	1.95	MVSI 15/100-S02	A	249 (50Hz) 235 (60Hz)	153	125	62-74**	106	9	4	24	61	65 (50Hz) 58 (60Hz)	103	100	117	-	-	M20x1,5
2.34	2.75	MVSI 15/200-S02	A	301	179	152	90	125	13	4	28	73	77	127	128	141	-	-	M20x1,5
3.33	3.50	MVSI 15/400-S02	A	344	203	167	105	140	13	4	30	82.5	93	145	140	160	-	-	M25x1,5
3.33	3.50	MVSI 15/550-S02	A	386	203	167	105	140	13	4	30	82.5	114	145	140	160	-	-	M25x1,5
3.48	3.43	MVSI 15/700-S02	A	394	216	205	120	170	17	4	45	93.5	106	170	160	182	-	-	M25x1,5
3.48	3.43	MVSI 15/900-S02	A	394	216	205	120	170	17	4	45	93.5	106	170	160	182	-	-	M25x1,5
4.45	4.89	MVSI 15/1100-S02	A	435	225	205	120	170	17	4	54	104.5	117.5	187	162	203	-	-	M25x1,5
4.10	4.20	MVSI 15/1410-S02	A	448	246	230	140	190	17	4	54	116	108	207	190	225	-	-	M25x1,5
4.29	4.89	MVSI 15/1710-S02	A	500	246	230	140	190	17	4	54	116	134	207	190	225	-	-	M25x1,5
4.30	4.90	MVSI 15/2000-S02	A	574	246	230	140	190	17	4	54	116	171	207	180	225	-	-	M25x1,5
6.09	7.23	MVSI 15/2410-S08	A	537	272	275	155	225	22	4	70	130	137	238	210	253	-	-	M25x1,5
6.50	7.50	MVSI 15/3000-S08	A	617	272	275	155	225	22	4	70	130	177	238	210	253	-	-	M25x1,5
7.11	6.92	MVSI 15/3810-S02	A	584	321	310	155	255	23.5	4	77	157	137	277	215	295	-	-	M25x1,5
5.90	7.10	MVSI 15/4300-S02	A	666 (50Hz) 584 (60Hz)	321	310	155	255	23.5	4	77	157	178 (50Hz) 137 (60Hz)	277	215	295	-	-	M25x1,5
7.02	8.00	MVSI 15/5010-S02	A	630	347	340	180	280	26	4	80	165	150	303	240	320	-	-	M32x1,5
7.02	8.00	MVSI 15/6000-S02	A	630	347	340	180	280	26	4	80	165	150	303	240	320	-	-	M32x1,5
6.48	7.67	MVSI 15/7000-S02	A	680	370	390	200	320	28	4	90	180	160	330	270	350	-	-	M32x1,5
5.43	5.57	MVSI 15/9000-S90	A	629	395	392	200	320	28	4	100	192	134,5	355	270	375	-	-	M32x1,5
6.56	6.67	MVSI 15/9500-S02	C	862	437	460	125	380	39	6	35	215	230	387	320	414	-	-	M32x1,5
7.03	8.00	MVSI 15/11500-S90	C	990	454	530	140	440	45	6	38	230	240	423	370	448	-	-	M32x1,5
8.00	8.00	MVSI 15/14500-S90	C	990	454	530	140	440	45	6	38	230	240	423	370	448	-	-	M32x1,5

Három fázisú

1.20	1.30	MVSI 15/35-S02	A	211	153	125	62-74**	106	9	4	24	61	46	103	100	117	3.15	25	M20x1,5
1.20	1.30	MVSI 15/80-S02	A	235	153	125	62-74**	106	9	4	24	61	58	103	100	117	3.15	25	M20x1,5
1.20	1.30	MVSI 15/100-S02	A	249 (50Hz) 235 (60Hz)	153	125	62-74**	106	9	4	24	61	65 (50Hz) 58 (60Hz)	103	100	117	3.15	25	M20x1,5
1.50	1.85	MVSI 15/200-S02	A	301	179	152	90	125	13	4	28	73	77	127	128	141	5	25	M20x1,5
2.50	2.21	MVSI 15/400-S02	A	344	203	167	105	140	13	4	30	82.5	93	145	140	160	32/12	35	M25x1,5
2.50	2.21	MVSI 15/550-S02	A	386	203	167	105	140	13	4	30	82.5	114	145	140	160	32/12	40/35	M25x1,5
5.44	3.63	MVSI 15/700-S02	A	381	210	205	120	170	17	4	45	91.5	88	168	160	178	96/16	160/40	M25x1,5

Egy fázisú

** Egyes modellek rögzítése a talp lyuk ovális kialakítása miatt több méretben is lehetséges.

○ indító / üzemi kondenzátor.



6 Pólus - 1000/1200 ford./perc

	Termék választék				Mechanikus tulajdonságok								Elektromos tulajdonságok			
	Kód	Tipusjel	Építési nagyság SF*	II2D Hőm. osztály Ex	Statikus nyomaték* kgmm		Centrifugális erő kN				Tömeg kg		Max. teljesítmény W		Max. áram A	
					50 Hz	60 Hz	50 Hz	60 Hz	50 Hz	60 Hz	50 Hz	60 Hz	50 Hz	60 Hz	400 V 50 Hz	460 V 60 Hz
Három fázisú	602296	MVSI 10/40-S02	10	• 120°C	30.1	30.1	35.0	49.0	0.331	0.476	9.70	9.70	120	135	0.30	0.30
	602297	MVSI 10/100-S02	10	• 120°C	84.2	84.2	94.3	136	0.925	1.33	12.5	12.5	120	135	0.30	0.30
	602298	MVSI 10/200-S02	20	• 120°C	163	163	183	264	1.80	2.59	19.0	19.0	185	205	0.50	0.50
	602314	MVSI 10/310-S02	30	• 120°C	286	209	321	338	3.15	3.32	27.5	26.2	350	380	0.72	0.68
	602402	MVSI 10/550-S02	35	• 120°C	457	457	512	737	5.02	7.23	36.5	36.5	350	380	0.75	0.68
	602403	MVSI 10/650-S02	35	• 120°C	580	457	650	737	6.37	7.23	41.0	36.5	350	380	0.75	0.68
	602380	MVSI 10/810-S08	40	• 135°C	723	561	809	905	7.94	8.88	48.0	44.0	680	760	1.40	1.35
	602381	MVSI 10/1110-S08	50	• 135°C	1012	715	1132	1151	11.1	11.3	58.0	51.0	750	750	1.65	1.50
	602382	MVSI 10/1400-S08	50	• 170°C	1274	921	1424	1483	14.0	14.5	66.0	59.5	950	1000	1.80	1.70
	602406	MVSI 10/1610-S08	60	• 135°C	1464	962	1638	1549	16.1	15.2	83.0	71.0	1100	1300	2.20	2.20
	602407	MVSI 10/2100-S08	60	• 200°C	1927	1318	2154	2102	21.1	20.6	93.0	82.0	1500	1770	3.00	2.75
	602167	MVSI 10/2610-S02	70	• 135°C	2326	1720	2601	2747	25.5	26.9	130	116	1960	2100	4.10	3.75
	602230	MVSI 10/3000-S02	70	• 135°C	2690	1940	3007	3124	29.5	30.6	145	130	2200	2400	4.50	4.30
	602154	MVSI 10/3810-S02	80	• 135°C	3422	2380	3826	3831	37.5	37.6	188	170	2500	3000	5.10	5.00
	602204	MVSI 10/4700-S02	80	• 135°C	4206	2887	4701	4648	46.1	46.0	204	183	3200	3600	6.50	6.00
	602350	MVSI 10/5150-S02	80	• 135°C	4678	3230	5230	5200	51.3	51.0	225	200	3200	3600	6.50	6.00
	602138	MVSI 10/5200-S02	90	• 135°C	4658	3288	5208	5293	51.1	51.9	238	215	3800	4000	7.00	6.50
	602351	MVSI 10/5700-S02	90	• 135°C	5044	3478	5650	5600	55.4	54.9	240	220	3800	4000	7.00	6.50
	602091	MVSI 10/6500-S02	90	• 135°C	5838	4055	6527	6529	64.0	64.0	268	258	4300	5000	8.20	8.10
	602136	MVSI 10/6600-S02 [▲]	97	• 135°C	6083	3979	6799	6405	66.7	62.8	285	257	5000	5900	10.0	9.80
	602352	MVSI 10/7000-S02	90	• 135°C	6272	4348	7013	7000	68.8	68.7	275	263	4300	5000	8.20	8.10
	602092	MVSI 10/8000-S90	95	□ 135°C	7197	4967	8046	7996	78.9	78.4	315	277	7000	7500	12.6	11.3
	602093	MVSI 10/9000-S90	95	□ 135°C	7752	5385	8666	8669	85.0	85.0	326	289	7500	8200	14.0	12.9
	602137	MVSI 10/10000-S02	97	□ 135°C	8673	5664	9695	9117	95.1	89.4	381	340	7600	8000	13.5	12.4
	602349	MVSI 10/11200-S02	97	□ 135°C	9983	6896	11160	11100	109	109	405	370	7600	8000	13.5	12.4
	602134	MVSI 10/12000-S90 [▲]	100	□ 135°C	10996	7543	12294	12141	119	119	500	445	9000	9500	16.3	15.0
	602227	MVSI 10/13000-S02	97	□ 135°C	11510	8158	12867	13130	126	129	460	382	9600	10000	17.0	16.0
	602142	MVSI 10/15000-S02	105	□ 135°C	12662	8700	14155	14004	139	137	643	605	10600	11270	19.0	18.0
	602143	MVSI 10/17500-S02	105	□ 135°C	15500	10439	17327	16804	170	165	705	656	13000	13700	24.5	23.0
	602244	MVSI 10/19500-S02	105	□ 135°C	17947	11430	20062	18400	197	181	711	661	14000	14800	25.5	24.0
602144	MVSI 10/22000-S90	110	□ 135°C	20025	12533	22386	20208	220	198	926	896	19000	19000	33.0	25.5	
602273	MVSI 10/25000-S90	110	□ 135°C	22364	14785	25000	23800	245	233	960	928	19000	19000	33.0	25.5	
602336	MVSI 10/30000-S02	120	-	-	27285	18760	30560	30200	300	296	1200	1050	24000	25800	40.0	38.0

* Üzemi nyomaték = 2 x statikus nyomaték.

[▲] Speciális alkalmazásokra.

□ CSA-Tanúsítvány külön kérésre.

Ábra: A

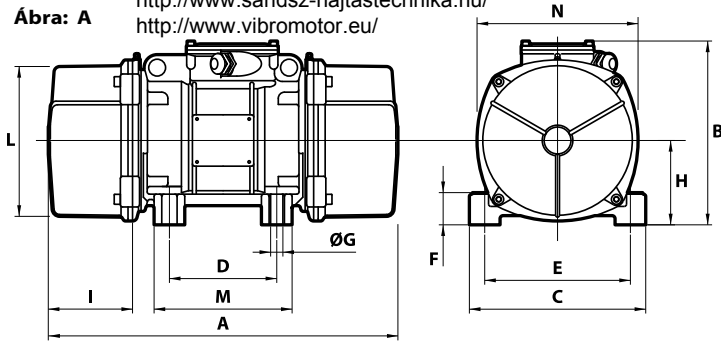

Ábra: C

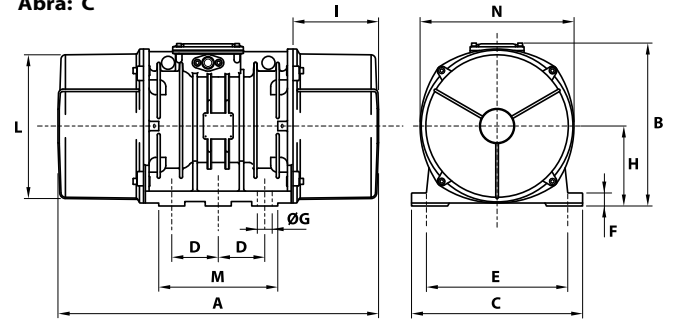

I _a /I _n		Tipusjel	Ábra	Méretek (mm)													
50 Hz	60 Hz			A	B	C	D	E	Furat		F	H	I	L	M	N	Kábel bevez.
									øG	N°							
1.90	2.07	MVSI 10/40-S02	A	255	179	152	90	125	13	4	28	73	54	127	128	141	M20x1,5
1.90	2.07	MVSI 10/100-S02	A	301	179	152	90	125	13	4	28	73	77	127	128	141	M20x1,5
2.72	3.10	MVSI 10/200-S02	A	344	203	167	105	140	13	4	30	82.5	93	145	140	160	M25x1,5
2.63	2.79	MVSI 10/310-S02	A	394	216	205	120	170	17	4	45	93.5	106	170	160	182	M25x1,5
2.53	3.68	MVSI 10/550-S02	A	435	225	205	120	170	17	4	54	104.5	117.5	187	162	203	M25x1,5
2.53	3.68	MVSI 10/650-S02	A	480 (50Hz) 435 (60Hz)	225	205	120	170	17	4	54	104.5	140 (50Hz) 117.5 (60Hz)	187	162	203	M25x1,5
2.79	3.33	MVSI 10/810-S08	A	500 (50Hz) 448 (60Hz)	246	230	140	190	17	4	54	116	134 (50Hz) 108 (60Hz)	207	190	225	M25x1,5
3.33	4.13	MVSI 10/1110-S08	A	574	246	230	140	190	17	4	54	116	171	207	190	225	M25x1,5
3.05	3.65	MVSI 10/1400-S08	A	574	246	230	140	190	17	4	54	116	171	207	190	225	M25x1,5
4.21	4.05	MVSI 10/1610-S08	A	617 (50Hz) 537 (60Hz)	272	275	155	225	22	4	70	130	177 (50Hz) 137 (60Hz)	238	210	253	M25x1,5
3.42	4.00	MVSI 10/2100-S08	A	617	272	275	155	225	22	4	70	130	177	238	210	253	M25x1,5
5.35	5.60	MVSI 10/2610-S02	A	666	321	310	155	255	23.5	4	77	157	178	277	215	295	M25x1,5
4.35	4.81	MVSI 10/3000-S02	A	712	321	310	155	255	23.5	4	77	157	201	277	215	295	M25x1,5
5.91	6.00	MVSI 10/3810-S02	A	734	347	340	180	280	26	4	80	165	202	303	240	320	M32x1,5
5.24	5.50	MVSI 10/4700-S02	A	796	347	340	180	280	26	4	80	165	233	303	240	320	M32x1,5
5.24	5.50	MVSI 10/5150-S02	A	826	347	340	180	280	26	4	80	165	248	303	240	320	M32x1,5
4.71	5.08	MVSI 10/5200-S02	A	744	370	390	200	320	28	4	90	180	192	330	270	350	M32x1,5
4.71	5.08	MVSI 10/5700-S02	A	840	370	390	200	320	28	4	90	180	240	330	270	350	M32x1,5
4.51	5.83	MVSI 10/6500-S02	A	840	370	390	200	320	28	4	90	180	240	330	270	350	M32x1,5
5.61	5.82	MVSI 10/6600-S02 ^Δ	C	750	437	460	125	380	39	6	35	215	174	387	320	414	M32x1,5
4.51	5.83	MVSI 10/7000-S02	A	840	370	390	200	320	28	4	90	180	240	330	270	350	M32x1,5
4.59	5.58	MVSI 10/8000-S90	A	870	395	392	200	320	28	4	100	192	255	355	270	375	M32x1,5
4.13	4.88	MVSI 10/9000-S90	A	870	395	392	200	320	28	4	100	192	255	355	270	375	M32x1,5
4.72	4.92	MVSI 10/10000-S02	C	862	437	460	125	380	39	6	35	215	230	387	320	414	M32x1,5
4.72	4.92	MVSI 10/11200-S02	C	912	437	460	125	380	39	6	35	215	255	387	320	414	M32x1,5
5.21	5.73	MVSI 10/12000-S90 ^Δ	C	990	454	530	140	440	45	6	38	230	240	423	370	448	M32x1,5
4.98	5.00	MVSI 10/13000-S02	C	1002	437	460	125	380	39	6	35	215	300	387	320	414	M32x1,5
5.88	5.78	MVSI 10/15000-S02	F	960	526	570	140	480	45	8	41	268	200	486	510	516	M32x1,5
5.71	5.96	MVSI 10/17500-S02	F	1040	526	570	140	480	45	8	41	268	240	486	510	516	M32x1,5
5.49	-	MVSI 10/19500-S02	F	1120	526	570	140	480	45	8	41	268	280	486	510	516	M32x1,5
4.67	5.88	MVSI 10/22000-S90	F	1150	607	610	140	520	45	8	38	297	297.5	542	510	582	M32x1,5
4.67	-	MVSI 10/25000-S90	F	1150	607	610	140	520	45	8	38	297	297.5	542	510	582	M32x1,5
4.89	5.39	MVSI 10/30000-S02	Q	1205	648	700	140	600	45	8	45	320	310	600	510	660	M32x1,5

I_a/I_n = Indító / max. névleges áram.

Egyes modellek rögzítése a talp lyuk ovális kialakítása miatt több méretben is lehetséges.

Ábra: F

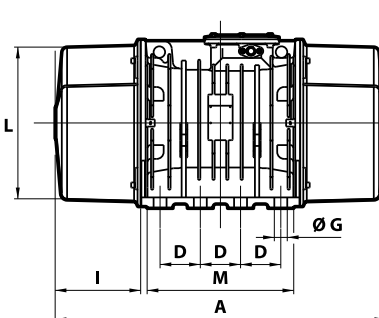

Ábra: Q

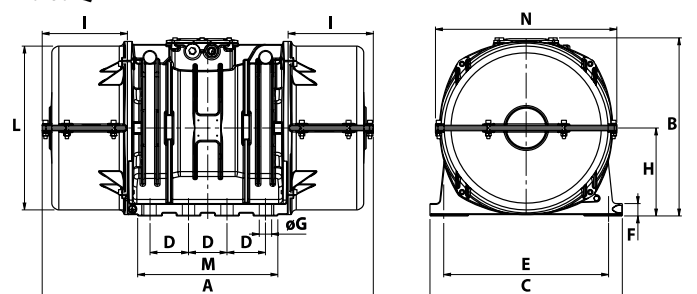



8 Pólus - 750/900 ford./perc

	Termék választék				Mechanikus tulajdonságok								Elektromos tulajdonságok			
	Kód	Típusjel	Építési nagyság	II2D Hőm. osztály	Statikus nyomaték*		Centrifugális erő				Tömeg		Max. teljesítmény		Max. áram	
					kgmm	kgmm	kg	kg	kN	kN	kg	kg	W	W	A	A
Három fázisú	602568	MVSI 075/150-S02	20	• 130°C	163	163	104	149	1.02	1.46	19.0	19.0	230	250	0.85	0.76
	602575	MVSI 075/250-S02	30	• 130°C	286	286	181	260	1.76	2.55	27.5	27.5	350	380	1.10	1.05
	602615	MVSI 075/400-S02	35	• 120°C	457	457	288	415	2.83	4.07	36.5	36.5	280	300	0.60	0.68
	602616	MVSI 075/530-S02	35	• 120°C	580	580	365	528	3.60	5.20	41.0	41.0	280	300	0.60	0.68
	602609	MVSI 075/660-S08	40	• 120°C	723	723	456	656	4.47	6.44	48.0	48.0	400	450	1.20	1.20
	602610	MVSI 075/910-S08	50	• 120°C	1012	1012	637	917	6.25	9.00	58.0	58.0	400	500	1.40	1.30
	602618	MVSI 075/1310-S08	60	• 150°C	1464	1464	922	1327	9.04	13.0	83.0	83.0	950	1100	2.20	2.20
	602619	MVSI 075/1750-S08	60	• 150°C	1927	1927	1214	1747	11.9	17.1	93.0	93.0	1100	1300	2.60	2.60
	602891	MVSI 075/2110-S02	70	• 135°C	2326	2326	1463	2107	14.4	20.7	130	130	1500	1790	4.10	4.20
	602884	MVSI 075/3110-S02	80	• 135°C	3422	3422	2152	3099	21.1	30.4	188	188	2000	2300	5.40	5.20
	602515	MVSI 075/3800-S02	80	• 135°C	4206	4206	2645	3808	25.9	37.4	204	204	2500	3000	6.00	6.00
	602862	MVSI 075/4200-S02	90	• 135°C	4658	4658	2930	4218	28.7	41.4	238	238	2800	3350	6.50	6.50
	602826	MVSI 075/5300-S02	90	• 135°C	5838	5838	3672	5287	36.0	51.9	268	268	4000	4300	8.20	7.85
	602827	MVSI 075/6500-S90	95	□ 135°C	7197	7197	4526	6517	44.4	63.9	315	315	4900	5800	9.90	9.50
	602551	MVSI 075/6800-S02 Δ	97	□ 135°C	7340	7340	4616	6647	45.3	65.2	330	330	5600	6000	10.5	10.0
	602870	MVSI 075/10000-S02	97	□ 135°C	12390	10973	7792	9937	76.4	97.5	438	419	6800	7450	13.2	12.0
	602863	MVSI 075/12000-S90	100	□ 135°C	13816	12407	8689	11235	85.2	110	540	520	7600	8300	14.0	13.5
	602871	MVSI 075/14000-S02	105	□ 135°C	17946	15500	11285	14036	111	138	702	680	9200	9600	21.0	19.5
602872	MVSI 075/17000-S02	105	□ 135°C	21337	19064	13418	17263	132	169	755	711	10400	11140	22.0	20.0	
602873	MVSI 075/22000-S90	110	□ 135°C	28633	24508	18005	22192	177	218	1015	981	12500	16200	26.5	28.0	
602535	MVSI 075/26000-S90	110	□ 135°C	-	28633	-	25927	-	254	-	1015	-	16200	-	28.0	
602589	MVSI 075/30000-S02	120	-	-	33440	33440	21070	30430	207	299	1125	1160	-	-	-	-

* Üzemi nyomaték = 2 x statikus nyomaték. Δ Speciális alkalmazásokra. □ CSA-Tanúsítvány külön kérésre.

Ábra: A

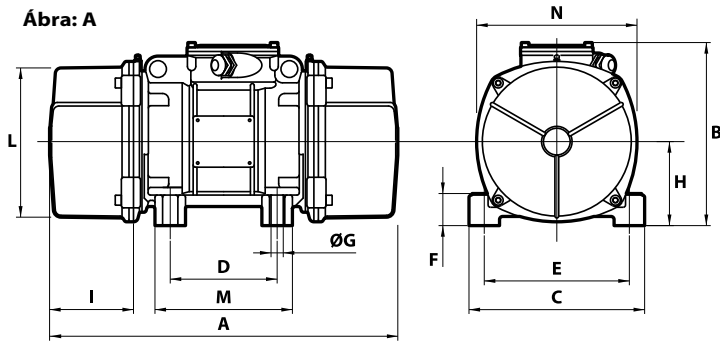

Ábra: C

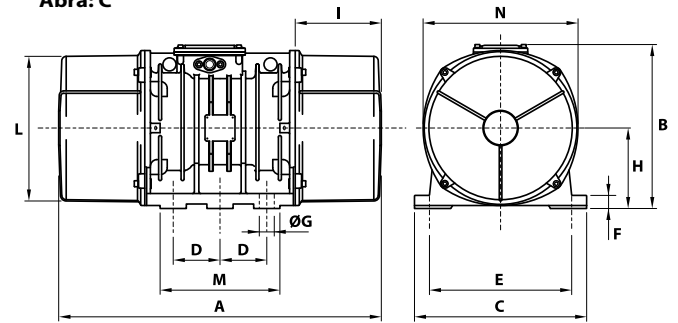

I _A /I _N		Tipusjel	Méretek (mm)														
50 Hz	60 Hz		Ábra	A	B	C	D	E	Furat		F	H	I	L	M	N	Kábel bevez.
									øG	N°							
2.13	2.11	MVSI 075/150-S02	A	344	203	167	105	140	13	4	30	82.5	93	145	140	160	M25x1,5
2.03	2.29	MVSI 075/250-S02	A	394	216	205	120	170	17	4	45	93.5	106	170	160	182	M25x1,5
1.73	2.94	MVSI 075/400-S02	A	435	225	205	120	170	17	4	54	104.5	117.5	187	162	203	M25x1,5
1.73	2.94	MVSI 075/530-S02	A	480	225	205	120	170	17	4	54	104.5	140	187	162	203	M25x1,5
2.38	2.58	MVSI 075/660-S08	A	500	246	230	140	190	17	4	54	116	134	207	190	225	M25x1,5
2.38	2.85	MVSI 075/910-S08	A	574	246	230	140	190	17	4	54	116	171	207	190	225	M25x1,5
2.63	3.41	MVSI 075/1310-S08	A	617	272	275	155	225	22	4	70	130	177	238	210	253	M25x1,5
2.78	3.04	MVSI 075/1750-S08	A	617	272	275	155	225	22	4	70	130	177	238	210	253	M25x1,5
3.55	2.95	MVSI 075/2110-S02	A	666	321	310	155	255	23.5	4	77	157	178	277	215	295	M25x1,5
3.98	4.62	MVSI 075/3110-S02	A	734	347	340	180	280	26	4	80	165	202	303	240	320	M32x1,5
4.00	4.20	MVSI 075/3800-S02	A	796	347	340	180	280	26	4	80	165	233	303	240	320	M32x1,5
3.84	4.00	MVSI 075/4200-S02	A	744	370	390	200	320	28	4	90	180	192	330	270	350	M32x1,5
3.87	5.35	MVSI 075/5300-S02	A	840	370	390	200	320	28	4	90	180	240	330	270	350	M32x1,5
3.04	3.26	MVSI 075/6500-S90	A	870	395	392	200	320	28	4	100	192	255	355	270	375	M32x1,5
3.12	3.30	MVSI 075/6800-S02	C	862	437	460	125	380	39	6	35	215	230	387	320	414	M32x1,5
3.33	3.92	MVSI 075/10000-S02	C	1002	437	460	125	380	39	6	35	215	300	387	320	414	M32x1,5
3.72	3.78	MVSI 075/12000-S90	C	1070	454	530	140	440	45	6	38	230	280	423	370	448	M32x1,5
4.99	5.44	MVSI 075/14000-S90	F	1040	526	570	140	480	45	8	41	268	240	486	510	516	M32x1,5
5.50	5.90	MVSI 075/17000-S90	F	1120	526	570	140	480	45	8	41	268	280	486	510	516	M32x1,5
5.63	4.71	MVSI 075/22000-S90	F	1150	607	610	140	520	45	8	38	297	297.5	542	510	582	M32x1,5
-	4.71	MVSI 075/26000-S90	F	1150	607	610	140	520	45	8	38	297	297.5	542	510	582	M32x1,5
-	-	MVSI 075/30000-S02	Q	1205	648	700	140	600	45	8	45	320	310	600	510	660	M32x1,5

I_A/I_N = Indító / max. névleges áram.

Egyes modellek rögzítése a talp lyuk ovális kialakítása miatt több méretben is lehetséges.

Ábra: F

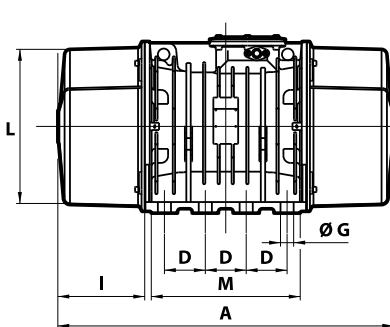

Ábra: Q

